

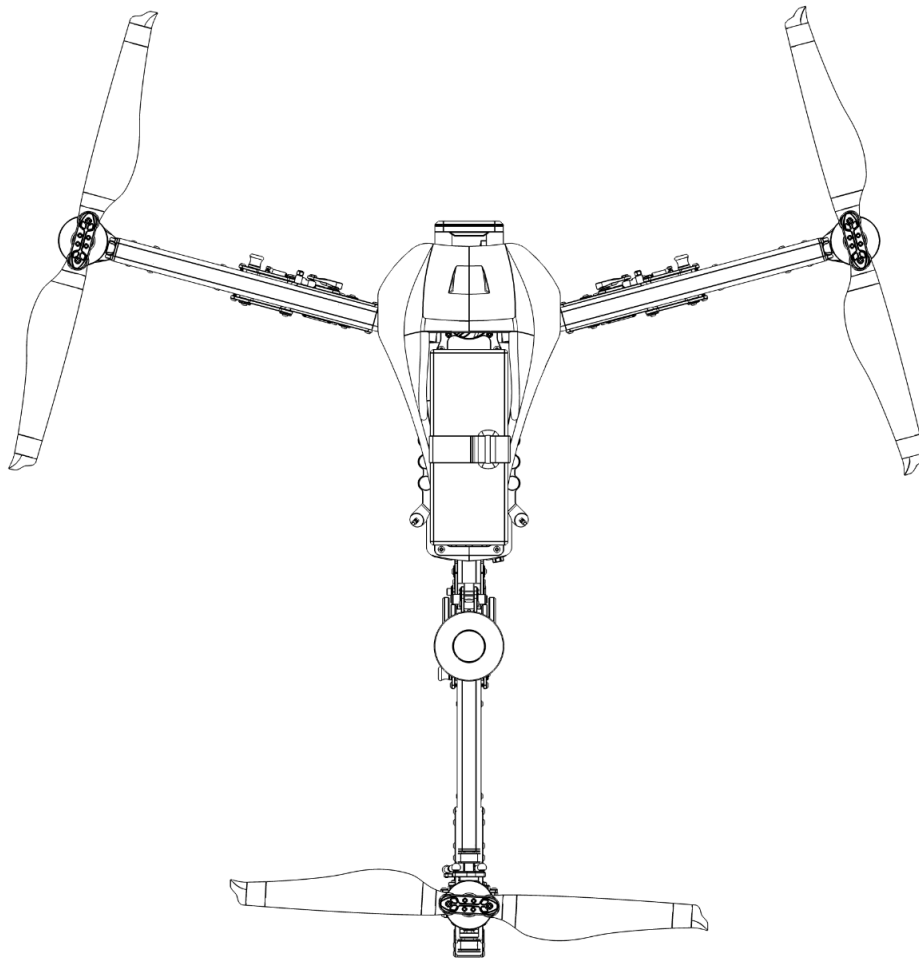

SwitchBlade-Elite Mark 2.5 Flight Checklist



Revision 2.1



Preflight Brief

- 1. Mission**
 - a. Risk assessment
 - b. Purpose
 - c. Accuracy / resolution
 - d. GNSS Ground Survey
- 2. Crew Resource Management (CRM)**
 - a. I'M SAFE checklist (for each crew member)
 - i. Illness
 - ii. Medication
 - iii. Sleep
 - iv. Alcohol
 - v. Fatigue
 - vi. Emotion
 - b. Delegate roles
 - i. RPIC
 - ii. Visual Observers (VO's)- as required
 - iii. Sensor Operators (SO's)- as required
 - iv. Data Quality Control (QC)- as required
 - c. Standardize communication
- 3. Airspace / Weather**
 - a. Hazards
 - b. LAANC clearance
 - c. NOTAMs
 - d. Current / future forecast
- 4. Emergencies**
 - a. Alternate landing sites
 - b. Delegate roles
 - c. Muster point
 - d. Downed Aircraft Recovery Plan (DARP)



Pre-Take Off

Before Power ON

- Unfold arms, deploy landing gear and GPS mast
- Ensure landing gear is fully engaged
- Spread rotor blades and inspect for damage
- Verify all rotor assembly screws and nuts are present and tight
- Attach payload-as required
- Power up GCS, verify power level and open Flight Deck
- Verify antennas on GCS are tight
- Visual inspection of aircraft
- Install vehicle batteries
- Power on aircraft

After Power ON

- Confirm navigation lights are working properly
- Confirm GPS satellites (10+ recommended)
- Confirm flight link (RSSI green)
- Confirm battery chemistry and power level
- Verify compass and aircraft heading is accurate
- Verify RTL Failsafes
 - Safe altitude above all obstacles
 - Low & critical battery warnings & vehicle actions
- Enable geofence- as required
- Verify Remote ID is broadcasting location
- Clear caution messages- as required
- Correct payload is selected- as required
- Upload mission- as required
- Payload checklist- as required



Takeoff

- Ensure flight & takeoff environment is clear
- Arm aircraft by moving the left stick down and right
 - Smoothly move the left stick back to fully down position
 - Smoothly move the left stick back to neutral
- Verify all rotors are spinning with the leading edge cutting into wind
- Initiate takeoff with full throttle climb
- Perform Aircraft Health Monitoring (AHM) check
 - Verify controls (roll, pitch, yaw)
 - Landing gear is in appropriate position
 - Verify appropriate battery voltage & amperage
 - Sensor is ON / recording data

Landing

- Perform Aircraft Health Monitoring (AHM) check
 - Landing gear is in appropriate position
 - Verify appropriate battery voltage & amperage
 - Verify flight & landing environment is clear
- Nose into the wind if > 10 Kts
- Smoothly land vehicle
- Disarm- Left stick down and full aft

Emergency Checklists

Uncontrolled Flight

 **WARNING:** Uncontrolled flight may be a result of pilot input or an uncommanded system input and distinguishing may not be readily apparent to operators. If an uncommanded input is not explained after recovery, pilots should land and discontinue flight until proper analysis can be conducted.

During any portion of the flight if the drone is not responding to pilot input perform the below steps:

1. Neutralize controls
 - a. Visually verify that no object or body part is being applied to the controls.
2. Brake mode- as required
3. RTL mode- as required
4. Land mode-as required
 - a. Maintain visual contact to determine landing location or note location on GCS
5. Emergency Disarm- as required

 **WARNING:** A departure of controlled flight may not always be recoverable. In the event of a “fly-away,” operators should be ready to alert airspace and agency authorities.

Disorientation

 **NOTE:** In either loss of visual contact or misperception of vehicle heading, the RPIC should consider the RTL function as the safest means to recover the vehicle. Maintaining situational awareness by continuously referencing GCS telemetry and FPV/payload video feed against visual location is the optimum means to avoid disorientation of any type.

In the event of loss of visual contact:

1. Reference telemetry on GCS
2. Yaw aircraft towards the intended landing site.
3. Climb aircraft above all known obstacles.
4. Fly aircraft directly to intended landing point or until visual contact is regained

In the event the vehicle is in sight but heading is misperceived:

1. One second orientation turns (as required)
2. Roll aircraft in same direction of previous yaw for one second
3. Determine direction of movement
4. Repeat until heading is verified

Lost Link “Communication Lost”

In the event of Lost Link:

1. Launch/Landing site: Ensure area is clear for RTL landing
2. Communication: Attempt to regain by resetting GCS and/or attaching charging source to device.
3. Launch/Landing Site: Monitor for safe vehicle recovery

In-Flight Battery Emergencies

In the event of **Low Battery** (RTL failsafe mode):

1. **Mode select:** Override RTL Mode if Manual Mode as desired or required.
2. **Landing site:** Identify landing site and ensure the area is clear.
3. **Landing sequence:**
 - a. If in RTL Mode: Monitor landing site and landing sequence while monitoring voltage.
 - b. If in Manual Mode: Maneuver vehicle to desired landing site while monitoring battery voltage.

In the event of **Critical Battery** (Landing failsafe mode):

1. **Mode select:** Override Landing Mode if Manual Mode is desired or required.
2. **Landing site:** Identify landing site and note location.
3. **Landing sequence:**
 - a. If in RTL Mode: Monitor landing site and landing sequence while monitoring voltage.
4. If in Manual Mode: Maneuver vehicle to desired landing site while monitoring battery voltage.

 **WARNING:** to critical voltage, vehicle will land in its immediate vicinity without operator action. In the event the operator overrides and continues extended flight, the vehicle may lose functional lift and will result in catastrophic loss of vehicle and potential damage loss of any persons/property in its flight path.

 **CAUTION:** Continued extended flight after RTL or Landing Mode has been engaged due to low voltage is not recommended.

Loss of GPS (Vehicle reverts to Altitude Hold)

In the event of Lost GPS:

1. Altitude: Climb to avoid all obstacles
2. Manually pilot vehicle referencing telemetry as needed.
3. Attempt to regain GPS enabled flight by switching to Manual mode.
4. Manual landing as required.

 **NOTE:** Loss of GPS will require the user to account for external forces like wind.

Yaw Malfunctions

Loss of Yaw control (Compromised tail or damaged/missing rotors):

Manually engage RTL

1. If RTL is unavailable or not desired, utilize a pulsing forward pitch movement in the direction of the landing zone.
2. If no payload is present, landing with gear up on a soft surface
3. If payload is present, land with gear deployed.
4. Position over intended landing site
5. At minimum hover (2-3 cm,) perform Emergency Disarm procedure

Failed Landing Gear

In the event of landing gear deployment malfunction:

1. Determine presence and type of payload
2. If no payload present: Belly land aircraft manually on a flat and level site.

 **NOTE:** Type of payload will predicate action taken for landing. Consideration should be given for survivability of payload over vehicle.

Partial failed landing gear with payload:

1. Landing gear: Cycle (If landing gear extends to full down, land as required)
2. Landing gear remains partially failed: return to landing site
3. Prepare site to land vehicle on substitute landing device (bush, piled up clothing, etc) to facilitate a level landing which protects the payload from impact.
4. At minimum hover (2-3 cm,) perform *Emergency Disarm* procedure

Full failed landing gear with payload:

1. Landing gear: Cycle (If landing gear extends full down, land as required)
2. Landing gear remains fully failed: Return to landing site
3. Prepare site to land vehicle on substitute landing device (trash can, bucket, etc) to facilitate a level landing which supports landing points and protects payload from impact.
4. At minimum hover (2-3 cm) perform *Emergency Disarm* procedure.

Loss of thrust

 **WARNING:** A loss of thrust may be indicated by an audible change in vehicle tone, erratic flight behaviors or fluctuations in current and voltage.

1. Control altitude-as required
2. Land as soon as possible
3. Emergency Disarm- as required
4. Discontinue flight until condition is corrected by a certified technician.

Emergency Disarm

 **WARNING:** Performing an Emergency Disarm will result in the immediate disable of the vehicle rotor system regardless of given altitude or condition. An Emergency Disarm shall only be attempted when the operator intends for a complete loss of thrust and the rotors to stop.

1. Select the soft “ARMED” button on the top right of center portion of the GCS screen
2. GCS will display the following: EMERGENCY DISARM-Warning this will stop all motors. If the vehicle is in the air it will crash.
3. Slide to Confirm Emergency Disarm

Downed Aircraft Recovery Plan

1. Verify that all emergency response has concluded
2. Verify that the downed aircraft will not cause collateral damage through a fire
3. or fluid leak
4. Send power down command to the aircraft
5. Power down control and communications equipment
6. Secure the project site. Stow all equipment and supplies not required for the
7. aircraft recovery effort
8. Is the aircraft on public or private property?
9. PRIVATE – Contact the landowner before continuing with the recovery
10. PUBLIC – Continue with the recovery
11. Can the aircraft be accessed safely?
12. NO – Contact client representatives or qualified contractor for
13. assistance
14. YES – Continue with recovery
15. Access the aircraft
16. Power down the aircraft
17. Remove the fuel source
18. Remove batteries
19. Close liquid fuel valve
20. Document the crash
21. Take photographs, make notes and sketches as needed
22. Remove the aircraft
23. Clean all debris from the site