

RESONON

PIKA L HYPERSPECTRAL CAMERA



The Pika L is a line-scan hyperspectral camera that covers the visible and near-infrared spectral range (400 – 1000 nm). The Pika L is lightweight and compact, ideal for remote sensing. It can be used with any of Resonon's benchtop, outdoor, and airborne systems, standalone with our software development kit, and integrated into machine vision systems.

FEATURES

- Spectral Range: 400 – 1000 nm
- 900 Spatial Pixels Per Line
- 281 Spectral Channels Per Line
- Lightweight and Compact (0.7 kg with lens)

SPECTRAL RESPONSE

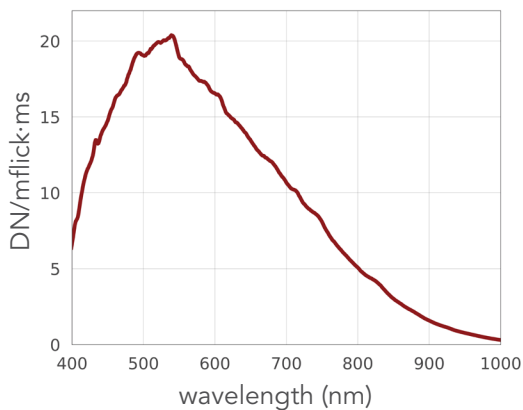

ACTUAL DATA

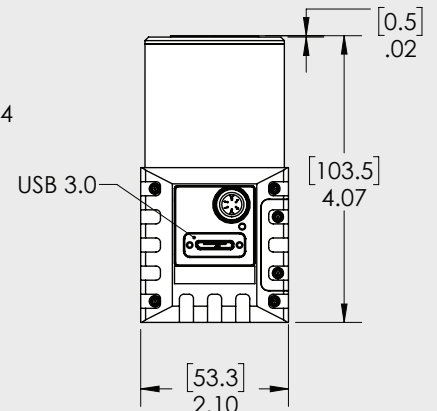
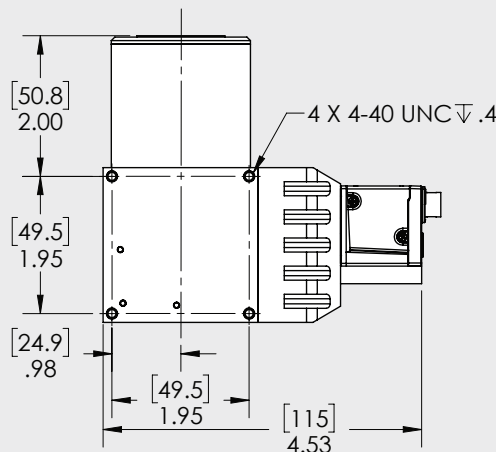
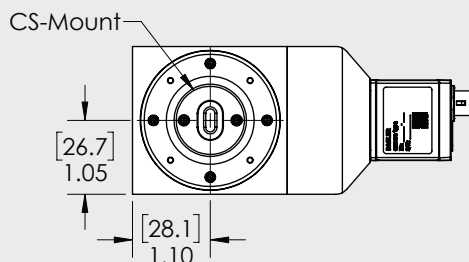
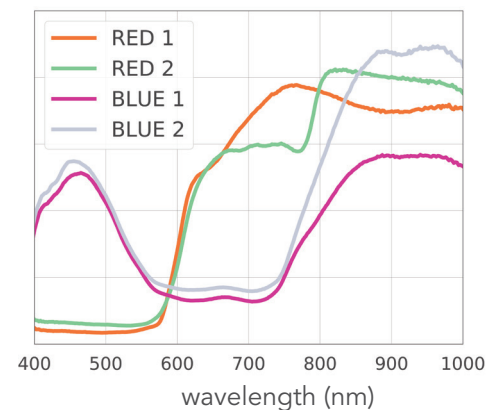

PIKA L SPECIFICATIONS

| | |
|---|---------------------------------|
| Spectral Range | 400 - 1000 nm |
| Spectral Channels^[1] | 281 |
| Spectral Bandwidth | 2.1 nm |
| Spectral Resolution (FWHM) | 3.3 nm |
| Dispersion per Pixel | 1.07 nm |
| Spatial Pixels per Line | 900 |
| f/# | 2.4 |
| Dimensions | 115 x 104 x 66 mm |
| Weight (without Lens) | 0.64 kg |
| Power Requirements | 3.4 W via USB |
| Max Frame Rate | 249 fps |
| Interface | USB 3.0 |
| Bit Depth | 12 |
| Pixel Size | 5.86 μ m |
| Peak SNR^[2] | 255 |
| Binning | spectral and spatial available |
| Pixel Well Depth | 32.7 ke- |
| Slit Width | 12 μ m |
| Spectrometer Magnification | 0.91 |
| Sensor Type | CMOS |
| Sensor Cooling | passive |
| Operating Temperature (non-condensing) | 0 to +50 C |
| Recommended Temperature (non-condensing) | +5 to +40 C |
| Objective Lens Mount | CS-mount |
| Objective Lens Field-Of-View Options | 4°, 6°, 13°, 18°, 25°, 37°, 47° |
| Software Development Kit | Windows, C++ |

[1] This is the number of spectral channels spanning 400 – 1000 nm. The total number of spectral channels delivered by the Pika L is 300, with bands extending beyond both edges of the Spectral Range.

[2] This value obtained at minimum binning. SNR can be increased with spectral and spatial binning.

Sample data and hyperspectral analysis software are available for free download at downloads.resonon.com. Resonon provides a programming guidance document for integrating our imagers using readily available SDKs.